

FBs-1HLC5 Single Channel Stand-alone Load Cell Input Module

V1.0

Introduction

FBs-1HLC5 is one of the analog input stand-alone modules of FATEK FBs series PLC. It provides RS-485 communication interface and 16-bits precise resolution. It can be used for 4-wire or 6-wire load cell input in weight measurement. It also provides five types of scan rate (6.25/12.5/25/50/100Hz)to meet customer's requirement.

Dimension

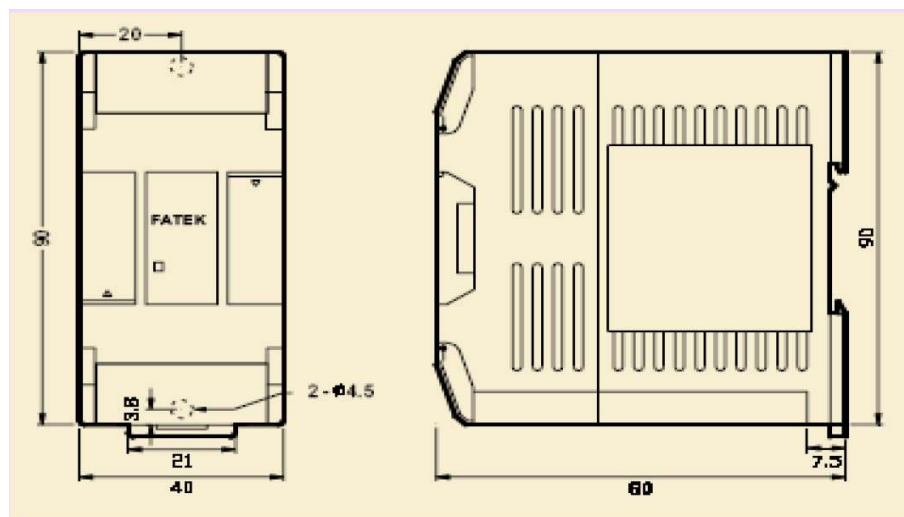

Specifications

Total Channels	1CH
Resolution	16-bit
Conversion Rate	6.25/12.5/25/50/100 Hz
Excitation Voltage	5V, +/-5%, 120mA
Sensitivity	1mV/V, 2mV/V, 4mV/V, 5mV/V
Communication Interface	RS-485
Sensor Type	4-wire or 6-wire Load Cell
Number of Sensor Connection	8 * 350Ω Sensor
Indicator(s)	5V POWER LED MD: Indication for unstable weigh measurement ZERO: Indication for gross weigh measurement = 0 NET: Indication for net weigh measurement GROSS: Indication for gross weigh measurement
Supply Power	24V-15%/+20%, 2VA
Operating Temperature	0 ~ 50 °C

Storage Temperature	-20 ~ 80 °C
Dimensions	40(W)x90(H)x80(D) mm
Weight	120g

Wiring Diagram

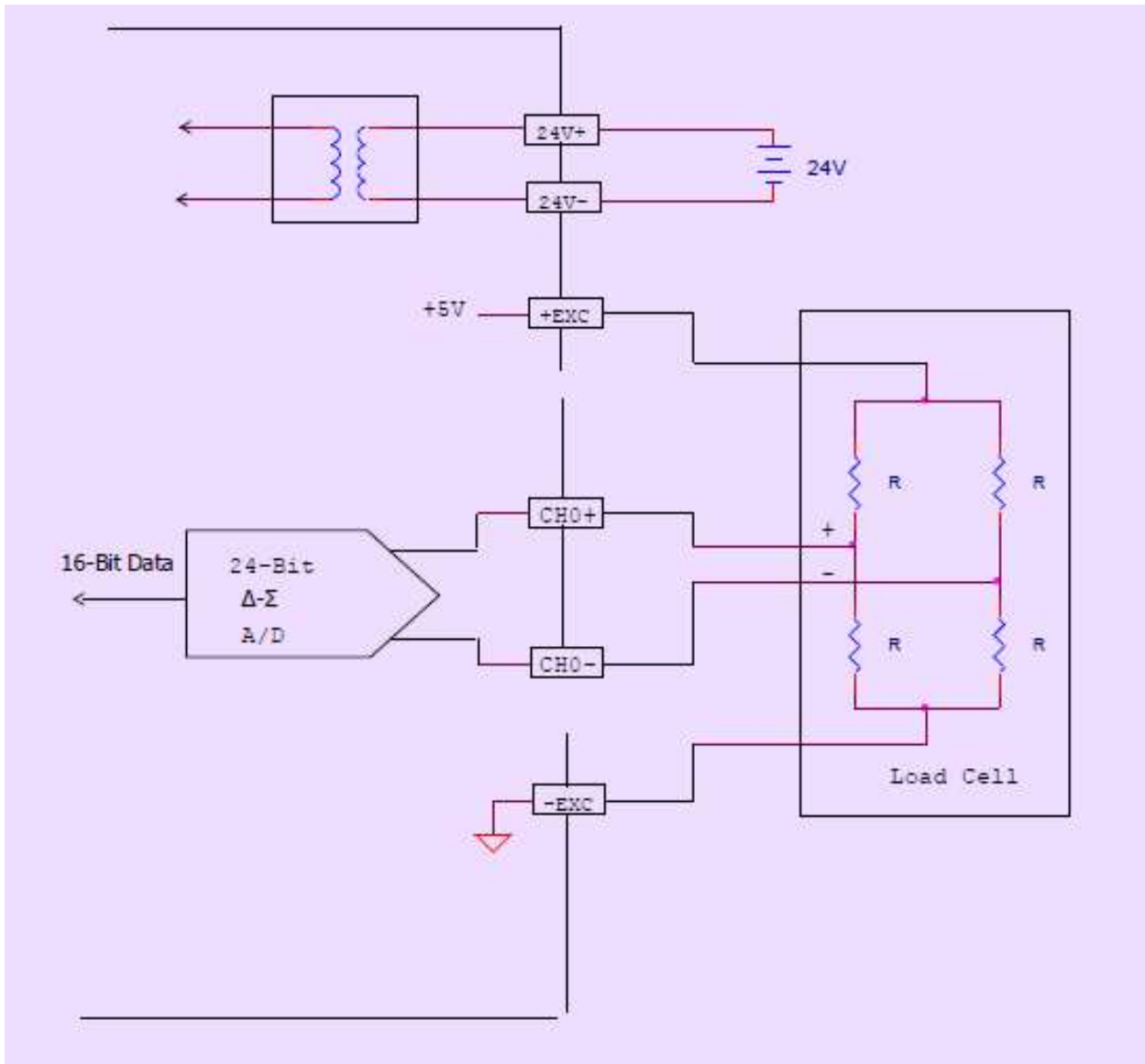

Appendix - MODBUS DATA ADDRESS

RS-485 / 232 Parameter Setting Table

Address	Function	Value	Size	R/W
41025	Number of Station	0 ~ 255	Word	R/W
41026	Baud Rate	0: 9600 1: 19200 2: 38400 3: 57600	Word	R/W

ERROR MESSAGE

Address	Function	Value	Size	R/W
41793	Calibration Error Message	0 ~ 3	Word	R/W

CSP (Calibration Setting Parameter)

Address	Function	Value	Size	R/W
42049	AD Sampling Rate	0: 100Hz 1: 50HZ 2: 25Hz 3:12.5Hz 4:6.25Hz	Word	R/W
42052	Minimum Scale	0: 1 1: 2 2: 5 3: 10 4: 20 5: 50	Word	R/W
42053	Zero Tracking Time	0.00 ~ 10.0 sec. (Default 1.0 sec.)	Word	R/W
42054	Zero Tracking Range	0.00 ~ 10.0 scale (Default 0.5D)	Word	R/W
42055	Unstable Tracking Time	0.00 ~ 10.0 sec. (Default 1.0 sec.)	Word	R/W
42056	Unstable Tracking Range	0.00 ~ 10.0 scale (Default 0.5D)	Word	R/W
40275	Zero Range	0 ~ 9999999	2Word	R/W

Calibration Memory Map

Address	Function	Value	Size	R/W
42305	AD Internal Value		2Word	R
42307	Display Value		2Word	R
42309	Gross Weight		2Word	R
42311	Net Weight		2Word	R
42315	Tare Weight		2Word	R
42561	Max. Weight	0 ~ 9999999 (Default 9999999)	2Word	R/W
42563	Zero Display Value	0 ~ 9999999 (Default 35000)	2Word	R/W
42565	SPAN 1 Display Value	0 ~ 9999999 (Default 250000)	2Word	R/W
42567	SPAN 1 Weight Value	0 ~ 9999999 (Default 20000)	2Word	R/W
42569	SPAN 2 Display Value	0 ~ 9999999 (Default 0)	2Word	R/W
42571	SPAN 2 Weight Value	0 ~ 9999999 (Default 0)	2Word	R/W
42573	SPAN 3 Display Value	0 ~ 9999999 (Default 0)	2Word	R/W
42575	SPAN 3 Weight Value	0 ~ 9999999 (Default 0)	2Word	R/W

Flag Memory Map

Address	Function	Size	R/W	Address	Function	Size	R/W
0002	Over-loading	Bit	R	0513	Calibration Zero Key	Bit	W
0005	Gross Weight	Bit	R	0514	Calibration SPAN 1 Key	Bit	W
0006	Net Weight	Bit	R	0515	Calibration SPAN 2 Key	Bit	W
0007	Zero	Bit	R	0516	Calibration SPAN 3 Key	Bit	W
0008	Unstable	Bit	R				
0010	Zero Band	Bit	R	0769	Initialize Calibration Parameters	Bit	W
				0770	Initialize All Parameters	Bit	W
0257	Return Zero	Bit	W	0771	Initialize Function Parameters	Bit	W
0258	Weight Deduct	Bit	W	0772	Clear Measurement Data	Bit	W
0259	Switch "Net/Gross" Weight	Bit	W	0773	Save EEP	Bit	W
0263	Clear " Weight Deduct"	Bit	W				